

PRODUCT TITLE

18g PREFORM

DRAWING NUMBER

E928-P-01

ref PET PLAS drg P-0102 iss2

ISSUE NUMBER

1

MATERIAL

PET

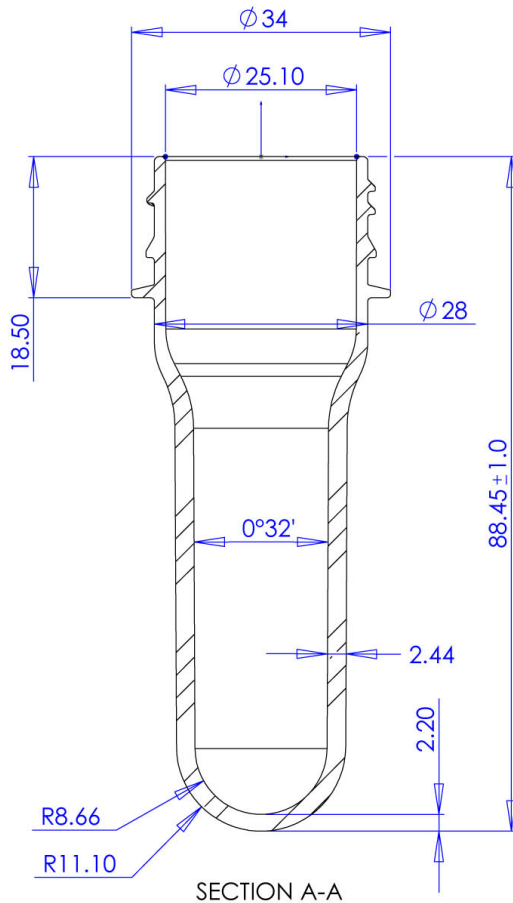

SECTION A-A

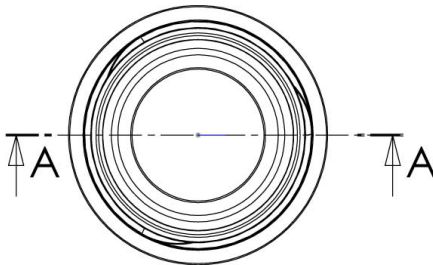

CAPACITY @ FILL LEVEL
@ 20°C after 72hrs

...

CAPACITY @ BRIMFULL
@ 20°C after 72hrs

...

NECK FINISH

30-25 HIGH

DESIGN WEIGHT

18g

ALTERNATIVE WEIGHTS

...

TOOLING REF

Y049

DIMENSIONS

ALL DIMENSIONS IN MILLIMETERS UNLESS OTHERWISE STATED

ALL DIMENSIONS SHOWN ARE A REPRESENTATION AND ARE SUBJECT TO CHANGE

UNLESS STATED GENERAL TOLERANCES FOR BLOWN PARTS = ± 0.5 mm

UNLESS STATED GENERAL TOLERANCES FOR INJECTED PARTS = ± 0.2 mm

HEAD OFFICE

ESTERFORM PACKAGING LIMITED
BORASTON LANE
TENBURY WELLS
WORCESTERSHIRE
WR15 8LE, UK

Phone : +44 (0) 1584 810 600
Fax : +44 (0) 1584 810 213

THIS DRAWING AND THE COPYRIGHT THEREON ARE THE PROPERTY OF ESTERFORM LTD AND MUST NOT BE REPRODUCED IN PART OR IN WHOLE OR PASSED ON TO OTHERS WITHOUT PERMISSION